



# Panel Pod

## Panel Pod Sensor

**Code:** AIRMLLED/POD/MWS

<b>Category</b>	Emergency
<b>Application</b>	Ancillary, Commercial, Education, Healthcare, Industrial, Retail
<b>Specification</b>	Performance

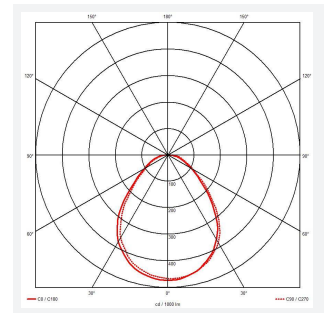
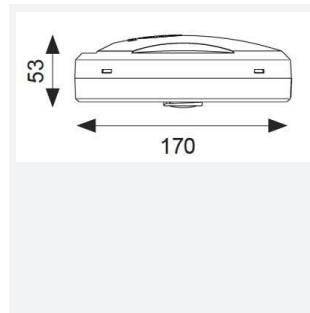
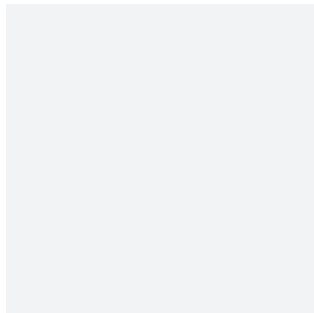
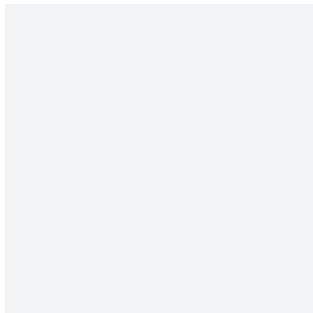

### PRODUCT FEATURES

- Converts Pace LED and Endurance LED panels to microwave sensor operation
- Simple twist and lock connection
- Fast and efficient installation
- Patent Protected. GB 3268665B (United Kingdom)
- Provides detection area of 360° with a detection angle of 120°
- Pre-wired 300mm 4-core flex for easy installation
- Adjustable time delay and distance
- Patent Protected. EP 3268665B (Europe)

### GENERAL INFORMATION

Input	220/240V
Operating Temp	0°C - 40°C
Product Weight without Packaging	0.294

### TECHNICAL INFORMATION

Colour / Finish	White
IP Rating	IP20
Class Protection	1
Internal / External	Internal
Warranty (Years)	5
CE Mark	Yes
Height	45 mm

